



**INTEGRATED WAREHOUSE  
RACKING + FORKLIFT SOLUTIONS**



# PALLET JACKS

# LPT40

## LITHIUM PALLET TRUCK

### LPT40 Li-Ion Powered Pallet Truck

Light and easy to operate, with super small power head, LPT40 is ideal for C-store, lift gate delivery fleets, and heavy-duty warehouse applications.

**STANDARD  
REMOVABLE SMART  
LITHIUM-ION BATTERY.**

ISS Equipment is committed to clean electric power. All our Big Joe forklifts come standard with LIST, Lithium Integrated Smart Truck technology for higher performance and clean air for people and products.



# LPT40 | LI-ION PALLET TRUCK

## CAPACITY

**1800kg**

## WEIGHT

**170kg** with battery

## EASY EXCHANGE LITHIUM ION BATTERY

**48-volt 20AH** rechargeable  
**240v 10A** Plug-in internal charger

## DRIVE AND TRAVEL CONTROLS

**24-volt** Curtis travel control  
with permanent magnet drive motor.  
Variable speed : 0 to 5.5 km/h empty  
Variable speed : 0 to 5 km/h loaded

## TYRES

Polyurethane:  
**Drive (1)**  $\Phi$  210x70  
**Load (2)**  $\Phi$  80x60 ( $\Phi$  74x88)

## OPTIONAL

- 1220mm load back rest
- Traction tyre
- Stability casters
- Extra Easy Exchange HD batteries with external charger to support an infinite duty cycle.

## FORKS

### 685mm OAW x 1150mm OAL

Designed for use with standard 1220mm pallets and other common skids and containers. Forks can achieve a maximum elevation of over 216mm and are built for heavy duty use and come standard with a robust fork entry roller for reliable pallet entry.

## ERGONOMIC CONTROL HEAD

Travel, lift/lower functions are located on the ergonomic control head for smooth operation with either hand, without the need to lift the hand from the loop handle. The bellybutton reversing switch and low mounted tiller arm improve operator comfort and easy steering. The head also includes dual butterfly travel controls, horn, battery discharge indicator (BDI) and manual lowering control for easy and efficient operation.

## SERVICEABILITY

Removable covers and modular design of components provides for easy maintenance with simple hand tools. Two piece drive wheel reduces complexity of tyre changes.

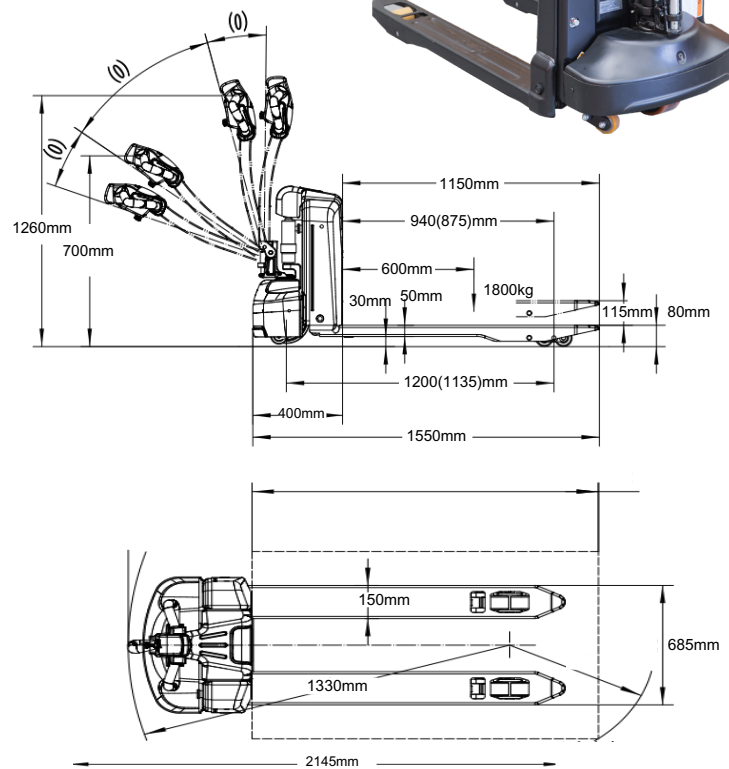

## HYDRAULICS

DC pump and chrome plated cylinder provide for smooth and efficient lifting.

## ELECTRICAL

Water resistant connectors and shrouded wiring harness supply power reliably to components. System includes an emergency power disconnect and covered on-board dock for the Easy Exchange HD Battery.

## BRAKES

Electromechanical brake provides good stopping power when handle is upright or lowered beyond the operating range.

## DUTY CYCLE

Revolutionary Easy Exchange HD Battery delivers up to 3.5 hours of operation and can be fully charged within 2 hours. Optional extra batteries can be purchased to extend run time or to serve as a reliable back-up.



## INTEGRATED WAREHOUSE RACKING + FORKLIFT SOLUTIONS

Transforming the way smart companies add efficiency to their warehousing and logistics operations.

📞 **134 234**

✉️ [sales@issequipment.com.au](mailto:sales@issequipment.com.au)

🌐 [issequipment.com.au](http://issequipment.com.au)

📍 17 Marconi Drive,  
South Dandenong VIC. 3175